

# Reduction of the magnetic pollution in urban areas by an active field cancellation

F. Garzia & A. Geri  
*Department of Electrical Engineering  
University of Rome "La Sapienza", Italy*

## Abstract

The authors propose an optimization procedure based on genetic algorithms able to aid the design of indoor MV/LV substations located in urban areas, reducing the magnetic field pollution within civil buildings outside the cabin. In particular, coupling genetic algorithms with a 3D magnetic field calculation code, an attempt was made to mitigate the magnetic field generated by a transformer substation using an active shield, consisting of a simple energized loop. From the analysis of the results, it emerges that the proposed approach may be advantageously used in order to mitigate the magnetic flux density in a room of a house bordered on an existing or a new MV/LV cabin.

*Keywords: magnetic pollution, active shielding, genetic algorithms, indoor MV/LV substations.*

## 1 Introduction

In urban areas, the indoor MV/LV transformer substations are usually located in proper rooms within civil structures or residential buildings. For this reason may be of great interest the mitigation of the magnetic field pollution produced by these cabins. In fact, Regulatory Standards impose, in several countries, the limits of the maximum magnetic flux density admissible for human exposure. Actually, in Italy, the discussion concerning the reduction of these limits has been closed: in an approved Degree (DCPM 8 luglio 2003 – G.U. N° 199 del 28 agosto 2003), the exposure has been fixed at 10  $\mu\text{T}$  for existing electrical power systems, and at 3  $\mu\text{T}$  for new ones.

## 1.1 MV/LV transformer substations

A typical indoor MV/LV transformer substation (fig. 1) has been considered in this study. It has input and output MV supply power cables, and two LV outgoing distribution cables, as shown in fig. 1. These distribution cables start from the power center (PC), which is a LV distribution switchboard installed downstream the MV/LV transformer. The PC and the LV distribution cables are usually critical sources in a MV/LV cabin, with respect to the problems related to magnetic pollution at power frequency. For this reason, the target volume has been deliberately located near both the PC and the LV outgoing distribution cables (fig. 1).

## 1.2 Shielding techniques

The shielding of indoor transformer substations may represent a challenge because of the known difficulties arising in the mitigation of magnetic field due to power plants at power frequency. The reduction of magnetic flux density produced by indoor MV/LV substations may be generally achieved using passive shield composed by ferromagnetic materials [1,2]. Active shielding has demonstrated to be a very interesting technique for the reduction of the magnetic field generated by power lines [3]. The number of variables to be controlled, in order to obtain good results in particular situations, may sometimes be very huge because it depends on the chosen shielding arrangement: in this situation, interesting results may be obtained using efficient optimization techniques such as those offered by GAs [4,5].

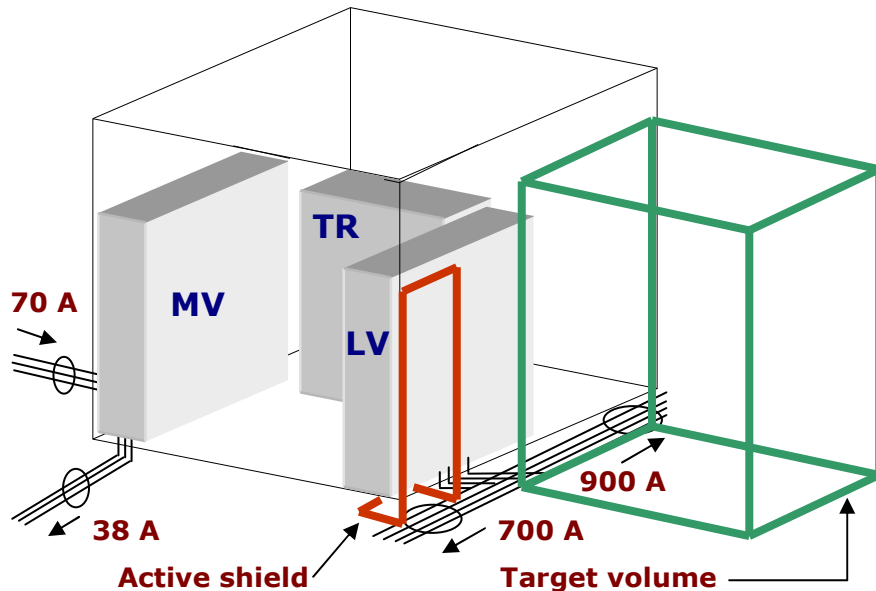

Figure 1. Schematic 3D view of an indoor MV/LV substation. The active shield loop and the target volume are also highlighted.

### 1.3 Proposed solution

In this paper, in order to design active shielding loops (e.g., consisting of a simple energized loop, fig. 1) which may be used to mitigate the magnetic pollution in previously defined volumes (called target volumes) outside an indoor MV/LV substation, a procedure, based on GAs coupled with a full 3D magnetic flux density calculation code [6,7,8,10], has been proposed. The design is aimed at assessing layout and excitation that may be used in order to reduce, in a target volume (e.g., located in a room of a house bordered on the cabin), the magnetic field below thresholds fixed by standards.

The proposed algorithm has been initially applied to study a simplified 2D configuration, in order to test the efficiency and the reliability of the code; then, it has been extended to achieve a fully 3D solution of the problem in real cases.

## 2 GA optimization procedure

Genetic algorithms are considered wide range numerical optimisation methods, which use the natural processes of evolution and genetic recombination. Thanks to their versatility, they can be used in various application fields [9].

GAs are particularly useful when the goal is to find an approximate global minimum in a high-dimension, multi-modal function domain, in a near-optimal manner. Unlike the most optimisation methods, they can easily handle discontinuous and non-differentiable functions.

The algorithms encode each parameters of the problem to be optimised into a proper sequence (where the alphabet used is generally binary) called a gene, and combine the different genes to constitute a chromosome. A proper set of chromosomes, called population, undergoes the Darwinian processes of natural selection, mating and mutation, creating new generations, until it reaches the final optimal solution under the selective pressure of the desired fitness function. GA optimisers, therefore, operate according to the following nine points:

1. encoding the solution parameters as genes;
2. creation of chromosomes as strings of genes;
3. initialisation of a starting population;
4. evaluation and assignment of fitness values to the individuals of the population;
5. reproduction by means of fitness-weighted selection of individuals belonging to the population;
6. recombination to produce recombined members;
7. mutation on the recombined members to produce the members of the next generation.
8. evaluation and assignment of fitness values to the individuals of the next generation;
9. convergence check.

The coding is a mapping from the parameter space to the chromosome space and it transforms the set of parameters, which is generally composed by real numbers, in a string characterized by a finite length. The parameters are coded into genes of the chromosome that allow the GA to evolve independently of the parameters themselves and therefore of the solution space (fig. 2).



Figure 2. Encoding of the solution parameters as genes of a chromosome consisting of 36 bit.

Once created the chromosomes it is necessary choose the number of them which composes the initial population.

This number strongly influences the efficiency of the algorithm in finding the optimal solution: a high number provides a better sampling of the solution space but slows the convergence. A good compromise consists in choosing a number of chromosomes varying between 5 and 10 times the number of bits in a chromosomes, even if in the most of situations, it is sufficient to use a population of 40-100 chromosomes and that does not depend of the length of the chromosome itself. The initial population can be chosen at random or it can be properly biased according to specific features of the considered problem (fig. 3). Fitness function, or cost function, or object function provides a measure of the goodness of a given chromosome and therefore the goodness of an individual within a population. Since the fitness function acts on the parameters themselves, it is necessary to decode the genes composing a given chromosome to calculate the fitness function of a certain individual of the population (fig. 3).

The reproduction takes place utilising a proper selection strategy which uses the fitness function to choose a certain number of good candidates. The individuals are assigned a space of a roulette wheel that is proportional to they fitness: the higher the fitness, the larger is the space assigned on the wheel and the higher is the probability to be selected at every wheel tournament. The tournament process is repeated until a reproduced population of  $N$  individuals is formed.

The recombination process selects at random two individuals of the reproduced population, called parents, crossing them to generate two new individuals called children.

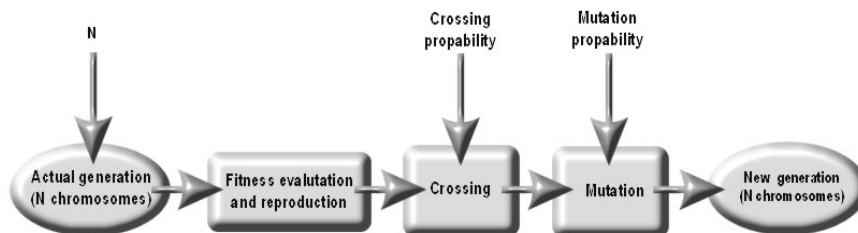

Figure 3. Operative scheme of GA iteration.

The simplest technique is represented by the single-point crossover, where, if the crossover probability overcome a fixed threshold, a random location in the parent's chromosome is selected and the portion of the chromosome preceding the selected point is copied from parent A to child A, and from parent B to child B, while the portion of chromosome of parent A following the random selected point is placed in the corresponding positions in child B, and vice versa for the remaining portion of parent B chromosome.

If the crossover probability is below a fixed threshold, the whole chromosome of parent A is copied into child A, and the same happens for parent B and child B. The crossover is useful to rearrange genes to produce better combinations of them and therefore more fit individuals. The recombination process has shown to be very important and it has been found that it should be applied with a probability varying between 0.6 and 0.8 to obtain the best results (fig. 3).

The mutation is used to survey parts of the solution space that are not represented by the current population. If the mutation probability overcomes a fixed threshold, an element in the string composing the chromosome is chosen at random and it is changed from 1 to 0 or vice versa, depending of its initial value. To obtain good results, it has been shown that mutations must occur with a low probability varying between 0.01 and 0.1 (fig. 3).

The converge check can use different criteria such as the absence of further improvements, the reaching of the desired goal or the reaching of a fixed maximum number of generations (fig. 3).

The optimization procedure reads, from a file, geometry and excitation currents of all conductors placed inside the cabin. Then it reads geometry and thresholds fixed by standards for target area/volume(s) chosen by the user. At this point, the procedure starts with the definition of possible geometrical arrangements and excitation currents for active shielding conductors.

Then, both geometries and excitations of shielding conductors are codified in terms of chromosomes (or individuals) of a population to be optimized by GAs. During the evolution process, the magnetic flux density is numerically computed by means of a calculation code, according to the previously defined 3D model of the cabin. The GA generates, at the end of the evolution process, optimal individuals, which correspond to geometrical arrangements of shielding conductors and their related currents. These individuals ensure the higher mitigation of magnetic flux density inside the target area/volume(s).

### **3 Numerical results**

#### **3.1 2D model**

In order to test the capability of the proposed method (with respect to the prediction of the best arrangement and excitation currents of the active shielding conductors) a simplified configuration (fig. 4a) has been initially studied by a 2D model. For an assigned configuration and excitation current of the main busbar of a PC installed in a MV/LV cabin, the GA optimization procedure has chosen the arrangement and excitation current of the active shielding conductors in such a way to mitigate the magnetic flux density inside the target area (fig. 4a). The results obtained are shown in figures 4b and 4c.

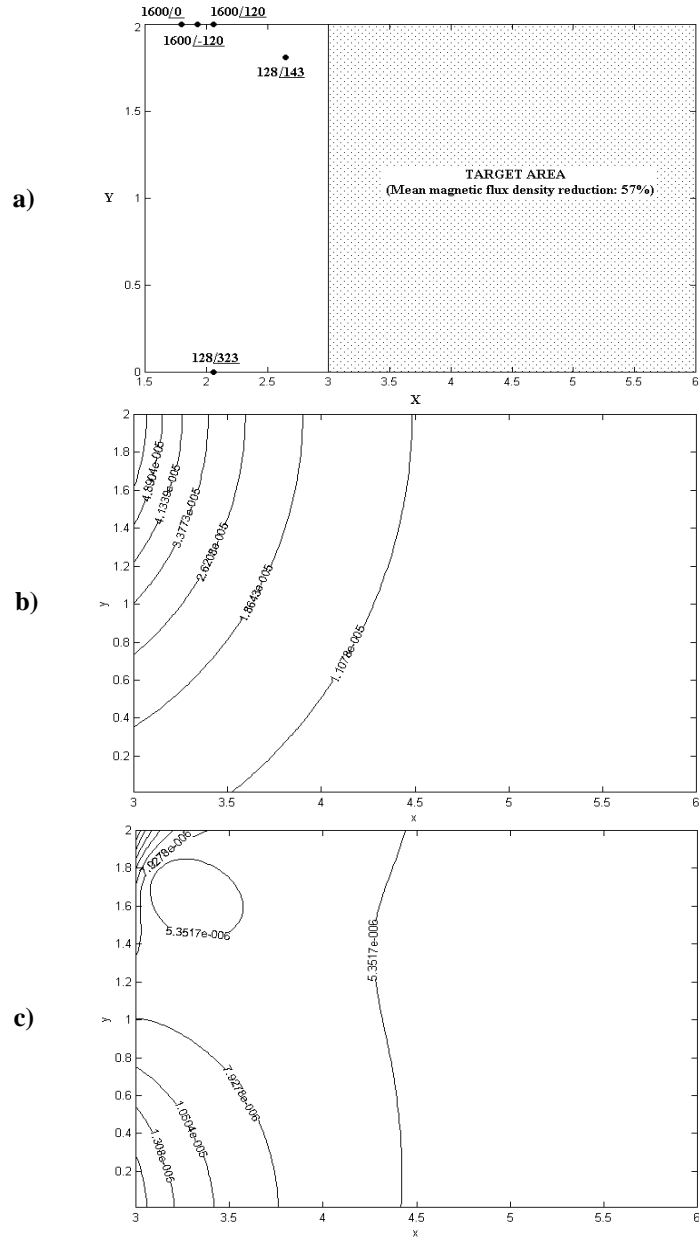

Figure 4. a) 2D system configuration (lengths in m) and current excitation (in A/°). Magnetic flux density (T) generated, in the target area, by the MV/LV cabin: b) without shielding; c) with the active shielding loop.

In particular, in these figures are respectively plotted the magnetic field density maps inside the target area when the active shield is absent (fig. 4b), and when it is working as fixed by the GA optimization procedure (fig. 4c). These tests have permitted to evaluate the efficiency and the reliability of predictions based on GA optimization procedure. The results are very hopeful: in fact, the mean value of the magnetic flux density computed inside the target area has been reduced of about 57%.

### 3.2 3D model

The GA optimization procedure has been also applied to study a typical indoor MV/LV transformer substation (fig. 1) by a full 3D model (fig. 5). In this case, main busbars, distribution busbars, connection cables, supply power cables and all their effective excitation currents have been modelled. The target volume has been chosen in such a way to include the space region, outside the cabin, which probably has the highest magnetic pollution.

The GA optimization procedure has been applied to study a typical indoor MV/LV transformer substation by a full 3D model. In this case, main busbars, distribution busbars, connection cables, supply power cables and all their effective excitation currents have been modelled. The target volume has been chosen in such a way to include the space region, outside the cabin, which probably has the highest magnetic pollution.

The geometrical configurations of the active shielding conductors have been limited to simple loops, each of which can also lie on two different planes (e.g., xz plane and/or yz plane, fig. 1). In this case, the conductors of the loop on the xz plane can be located, by the GA procedure, between the cabin wall and the PC, while, the conductors of the loop on the yz plane may be located over the PC (e.g., between 2 m and 3 mm of height) or under PC (e.g., at 200 mm below the ground level).

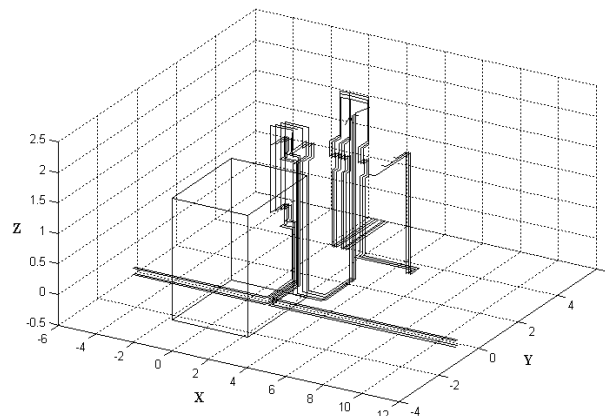

Figure 5. Layout (lengths in mm) and schematic 3D view (lengths in m) of the modified configuration of the MV/LV cabin under analysis. The PC has been shifted away from the wall (and then, the distance from the target volume has been increased of 500 mm).

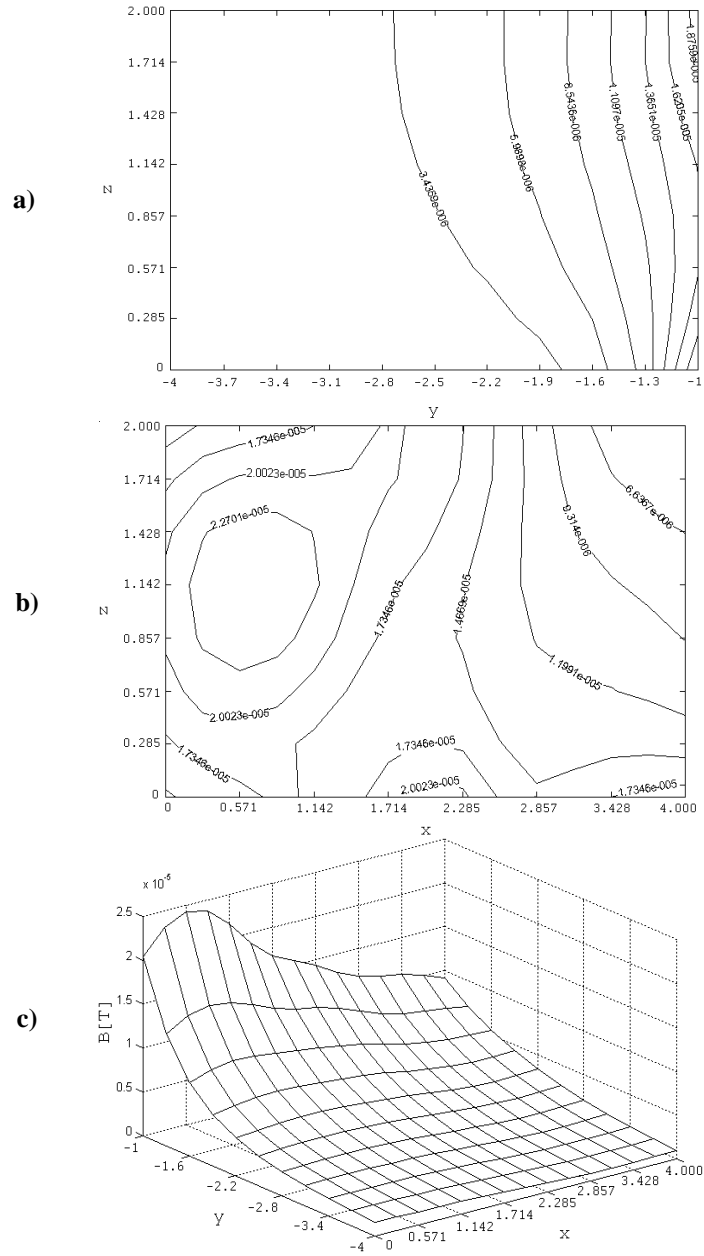

Figure 6. Magnetic flux density (T) generated, in the target volume, by the MV/LV cabin when the active loop works: a) Contour plot on a yz plane at x = 2 m; b) Contour plot on a xz plane at y = -1 m; c) surface plot on a xy plane at z = 1 m.



A synthetic description of the GAs operative principles has been given before. We want now describe the GAs implementation for the 3D problem under analysis. Since the horizontal part of the compensating structure has been considered to be placed at 20 cm below the ground level, it is immediate to verify that the whole structure is localized when are given the coordinates (x, y, z) of one point of the upper side of the vertical loop, a coordinate (x) of the other point at the same height but at the opposite side, and finally one coordinate (y) of the extreme points of the horizontal buried loop of the structure.

This means that the compensating structure is localized by means of 5 geometrical parameters. These parameters are represented by means of bits and it is necessary to choose the correct number of them, since a high number ensures a high precision but a slow velocity of the GA while a too low number of them ensure a high velocity of the GA but also a poor precision in the localization of the compensating structure (in fact, the optimal solution may be lost because of a not precise localization of the shielding loop). Due to the dimensions of the operative volume where the compensating structure can be placed (50 x 400 x 200 cm) a good compromise has demonstrated to the choice of 5 bits (32 values) to represent each geometrical parameter of compensating structure. It is also necessary to consider the current that flows inside the compensating structure. It is described in term of magnitude and phase. Since this current must varies as a function of the current that flows inside the conductors of the main busbar, its magnitude is represented as a percentage of the current that flows inside one of the mentioned conductors. The magnitude of this current has shown to be always less than 30% than the main current to obtain significant results and for this reason this percentage is represented using 5 bits (32 values). The phase of the current inside the compensating structure can vary between 0 and 360°: we choose to use 9 bits that allow of representing 512 numbers. Since the necessary numbers to codify the phase with a resolution equal to 1° are only 360, the remaining 152 values are used to represent the corresponding phase values between 0° and 152°, maintaining them active in the evolution process. A 8 bit encoding is not possible since it allows to represent only 256° with a resolution of 1° that is not enough for our purposes. The total length of the single chromosome is therefore equal to 39 bits. The magnetic flux density is numerically computed, during the evolution process, by means of a calculation code accounting for the fully 3D problem. The GA generates, at the end of the evolution process, optimal individuals, which correspond to geometrical arrangement of conductors and the related currents of the active shielding system that ensure the highest mitigation of magnetic flux density inside the target volume ( $0 < x < 4$  m,  $-4 < y < -1$  m,  $0 < z < 2$  m). A population of 100 individuals has shown to be sufficient to give good results in terms of computational performances of the GA procedure. The geometrical configuration of the optimized shielding system is shown in figure 5; while, in figures 6, the magnetic flux density maps are plotted. These results can be compared with those referring to the unshielded situation [10]. The magnetic flux density is reduced of about 28% (from 34  $\mu$ T to 24.3  $\mu$ T), after the installation of the active shielding system. A quite similar trend has been obtained for the mean value of the magnetic flux density inside the target volume (this is the value which pilots the evolution of the GA optimization procedure).

## 4 Conclusions and remarks

From the analysis of the results it is possible to conclude that the active shielding of indoor MV/LV substations can produce relevant reduction of the magnetic pollution in target volumes outside the cabins. This technique may be used both in new installations (when the magnetic flux density values are very critical in some regions outside the substations) and in existing cabins (when more restrictive limits must be respected). In addition, it has been also demonstrated that the GA optimization procedure, can be advantageously applied during the design of active shielding systems, which have the aim to mitigate, in assigned target volumes, the magnetic flux density produced by indoor MV/LV substations. The authors are working in order to generalize the proposed approach and to test its reliability in more realistic cases (i.e., when the excitation currents are unbalanced and/or they are also time varying).

## 5 Acknowledgments

This study has been financially supported by Provincia di Roma, Dipartimento n. 2 "Ambiente", Servizio n. 3 "Tutela dell'aria".

## References

- [1] Hasselgren, L., & Luomi, J., Geometrical Aspects of Magnetic Shielding at Extremely Low Frequencies, *IEEE Transaction on EMC*, 1995, pp. 409-420.
- [2] Rikitake, T., Magnetic and Electromagnetic Shielding, Terra Scientific Publishing Company, Tokyo, Japan, 1987.
- [3] Celozzi, S., "Active Compensation and Partial Shields for the Power-Frequency Magnetic Field Reduction", *Proc. of International Symposium on Electromagnetic Compatibility*, Minneapolis (USA), pp. 222-226.
- [4] Celozzi, S., & Garzia, F., "Active shielding for the power-frequency magnetic field reduction using genetic algorithm optimisation", in print.
- [5] Celozzi, S., & Garzia, F., "Magnetic field reduction by means of active shielding techniques", *Environmental Risk 2003*, WIT Press, Southampton (UK), pp.64-73, 2003.
- [6] Geri, A., Locatelli, A., & Veca, G. M., Magnetic fields generated by power lines, *IEEE Transactions on Magnetics*, 31(3), pp. 1508-1511, 1995.
- [7] Geri, A., & Veca, G. M., "Prediction of the magnetic pollution due to power lines", *Proc. of III International Congress Energy, Environment and Technological Innovation*, Caracas (Venezuela), 1, pp. 253-258, 1995.
- [8] Garzia, F., & Geri, A., "Active shielding design of indoor MV/LV substations using genetic algorithms optimization", *IEEE Symposium on Electromagnetic Compatibility*, Boston (USA), 1, pp.197-202, 2003.
- [9] Goldberg, D.E., *Genetic Algorithms in Search, Optimisation and Machine Learning*, Addison Wesley, 1989.
- [10] Geri, A., & Veca, G. M., "Power-frequency magnetic field calculation around an indoor transformer substation", submitted to *The Sustainable City 2004*, WIT Press, Siena (ITALY), 2004.