

# Active Shielding Design in a Full 3D Space of Indoor MV/LV Substations Using Genetic Algorithm Optimization

F. Garzia

Dept. of Electrical Engineering  
Univ. of Rome "La Sapienza"  
Rome, Italy  
email fabio.garzia@uniroma1.it

A. Geri

Dept. of Electrical Engineering  
Univ. of Rome "La Sapienza"  
Rome, Italy  
email alberto.geri@uniroma1.it

## Abstract

The authors propose an optimization procedure based on genetic algorithms (GAs) able to aid the design of indoor MV/LV substations, reducing the magnetic field pollution outside the cabin. In particular, coupling GAs with a 3D magnetic field calculation code, an attempt was made to mitigate the magnetic field outside the transformer substation by an active shield, consisting of a simple energized loop. The proposed algorithm has been initially applied to study a simplified 2D configuration, in order to test the efficiency and the reliability of the code; then, it has been extended to achieve a fully 3D solution of the problem. From the analysis of the results, it emerges that the proposed approach may be advantageously used in order to mitigate the magnetic flux density in target volumes located near MV/LV cabins.

## Keywords

Active Shielding, MV/LV Substation, Genetic Algorithm, Magnetic Field.

## INTRODUCTION

The shielding of indoor transformer substations (Fig. 1) may represent a challenge because of the known difficulties arising in the mitigation of magnetic field due to power plants at power frequency. Regulatory Standards impose in several countries the limits of the maximum magnetic flux density admissible for human exposure. Actually, in Italy, the discussion concerning the reduction of these limits is open. In particular, in a proposal Degree, an attempt to fix at  $10 \mu\text{T}$  for existing electrical power systems and at  $3 \mu\text{T}$  for new ones are going on. The reduction of magnetic flux density produced by indoor MV/LV substations may be generally achieved using passive shield composed by ferromagnetic materials [1][2]. Active shielding has demonstrated to be a very interesting technique for the reduction of the magnetic field generated by power lines [3]. The number of variables to be controlled, in order to obtain good results in particular situations, may sometimes be very huge because it depends on the chosen shielding arrangement: in this situation interesting results may be obtained using efficient optimization techniques such as those offered by GAs [4]. In this paper, a procedure based on GAs coupled with a full 3D magnetic flux density calculation code [5][6] has been proposed, in order to design active shielding loops which may be used to mitigate the magnetic

pollution in previously defined volumes (called target volumes) outside indoor MV/LV substations. The design is aimed at assessing layout and excitation that may be used in order to reduce, in target volumes, the magnetic field below thresholds fixed by standards.

## MV/LV CONFIGURATION

A typical indoor MV/LV transformer substation has been considered in this study. It has input and output MV supply power cables, and two LV outgoing distribution cables, as shown (see Fig. 1). These distribution cables start from the power center (PC), which is a LV distribution switchboard installed downstream the MV/LV transformer. The PC and the LV distribution cables are usually critical sources in a MV/LV cabin, with respect to the problems related to magnetic pollution at power frequency. For this reason, the target volume has been deliberately located near both the PC and the LV outgoing distribution cables (see Figures 3, 5 and 9).

## GA OPTIMIZATION PROCEDURE

The procedure reads, from a file, geometry and excitation currents of all conductors placed inside the cabin. Then it reads geometry and thresholds fixed by standards for target area/volume(s) chosen by the user. At this point, the procedure starts with the definition of possible geometrical arrangements and excitation currents for active shielding conductors.

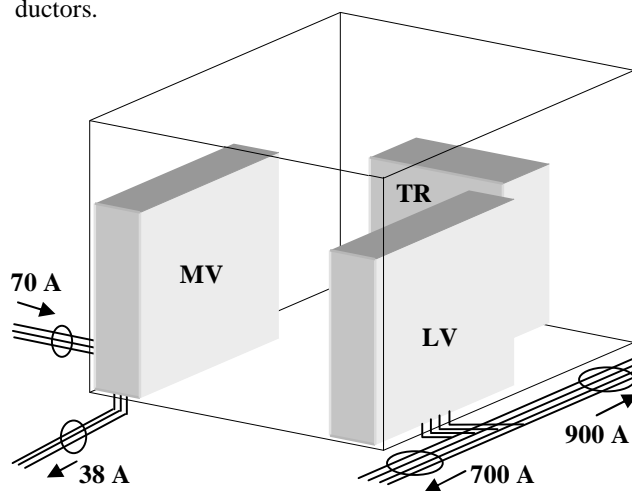

Figure 1. Schematic 3D view of an indoor MV/LV substation and its current excitation.

Then, both geometries and excitations of shielding conductors are codified in terms of chromosomes (or individuals) of a population to be optimized by GAs. During the evolution process, the magnetic flux density is numerically computed by means of a calculation code, according to the previously defined 2D/3D model of the cabin. The GA generates, at the end of the evolution process, optimal individuals, which correspond to geometrical arrangements of shielding conductors and their related currents. These individuals ensure the higher mitigation of magnetic flux density inside the target area/volume(s).

## NUMERICAL RESULTS

### 2D configuration

In order to test the capability of the proposed method (with respect to the prediction of the best arrangement and excitation currents of the active shielding conductors) a simplified configuration has been initially studied by a 2D model (Fig. 2). For an assigned configuration and excitation current of the main busbar of a PC installed in a MV/LV cabin, the GA optimization procedure has chosen the arrangement and excitation current of the active shielding conductors in such a way to mitigate the magnetic flux density inside the target volume (see Figure 3). The results obtained are shown in Figure 4. In particular, in Figures 4a and 4b are respectively plotted the magnetic field density maps inside the target area when the active shield is absent and when it is working as fixed by the GA optimization procedure. These tests have permitted to evaluate the efficiency and the reliability of predictions based on GA optimization procedure. The results are very hopeful: in fact, the mean value of the magnetic flux density computed inside the target area has been reduced of about 57%.

### 3D configuration

The GA optimization procedure has been also applied to study a typical indoor MV/LV transformer substation (see Figure 1) by a full 3D model (see Figure 5). In this case, main busbars, distribution busbars, connection cables, supply power cables and all their effective excitation currents have been modelled. The target volume has been chosen in such a way to include the space region, outside the cabin, which probably has the highest magnetic pollution.

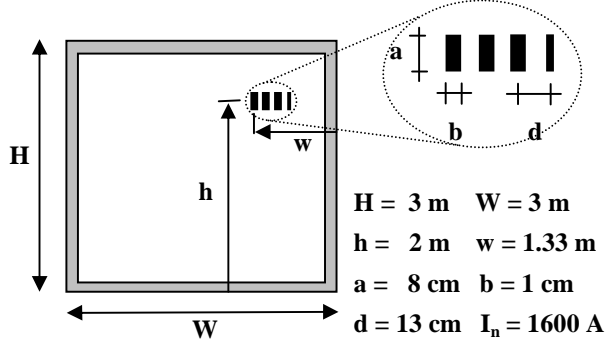

Figure 2. Simplified 2D configuration of the indoor MV/LV substation.

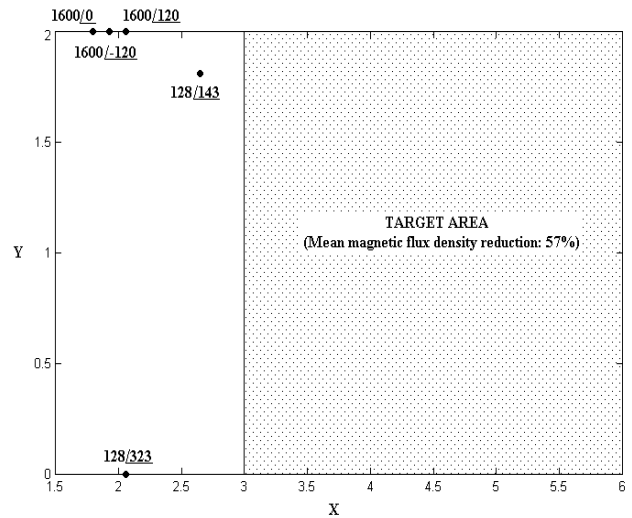

Figure 3. 2D system configuration (lengths in m) and current excitation (in A).

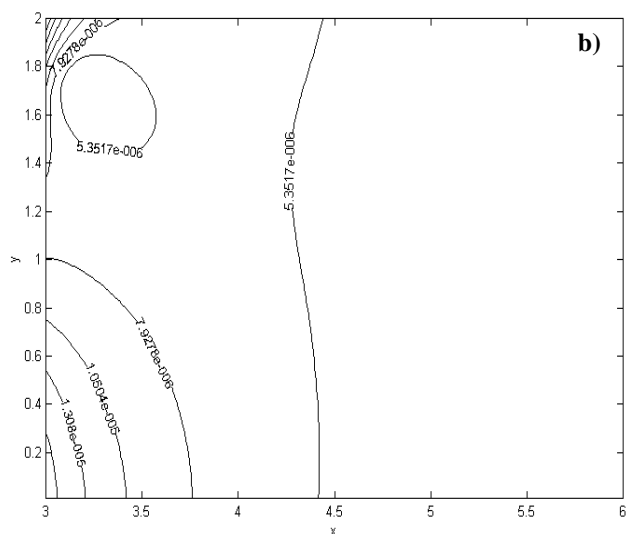
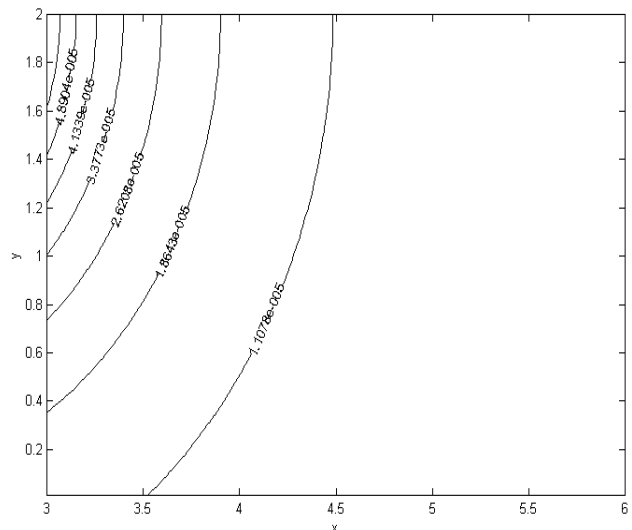

Figure 4. Magnetic flux density (T) in the target area: a) without shielding; b) with the active shielding loop.

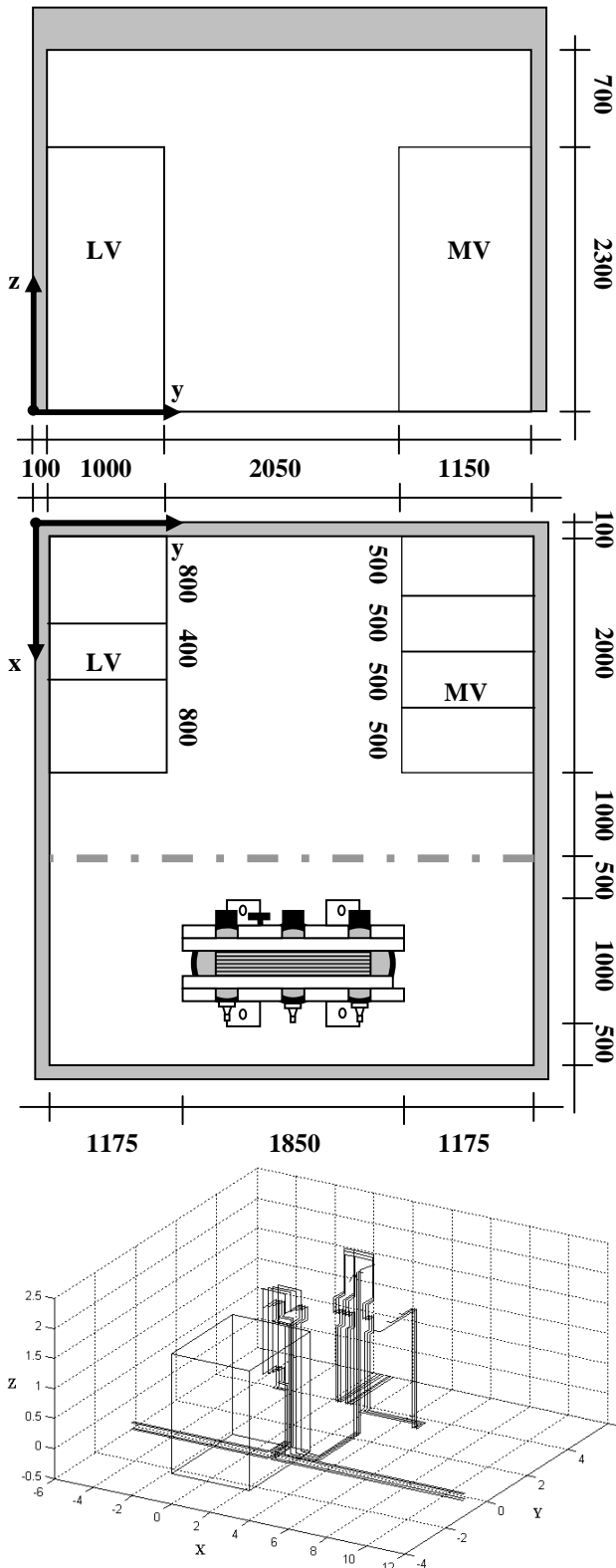

Figure 5. Original configuration of a typical indoor MV/LV substation: layout (lengths in mm) and schematic 3D view (lengths in m) of main busbars, distribution busbars, connection cables and supply power cables. The target volume is also highlighted.

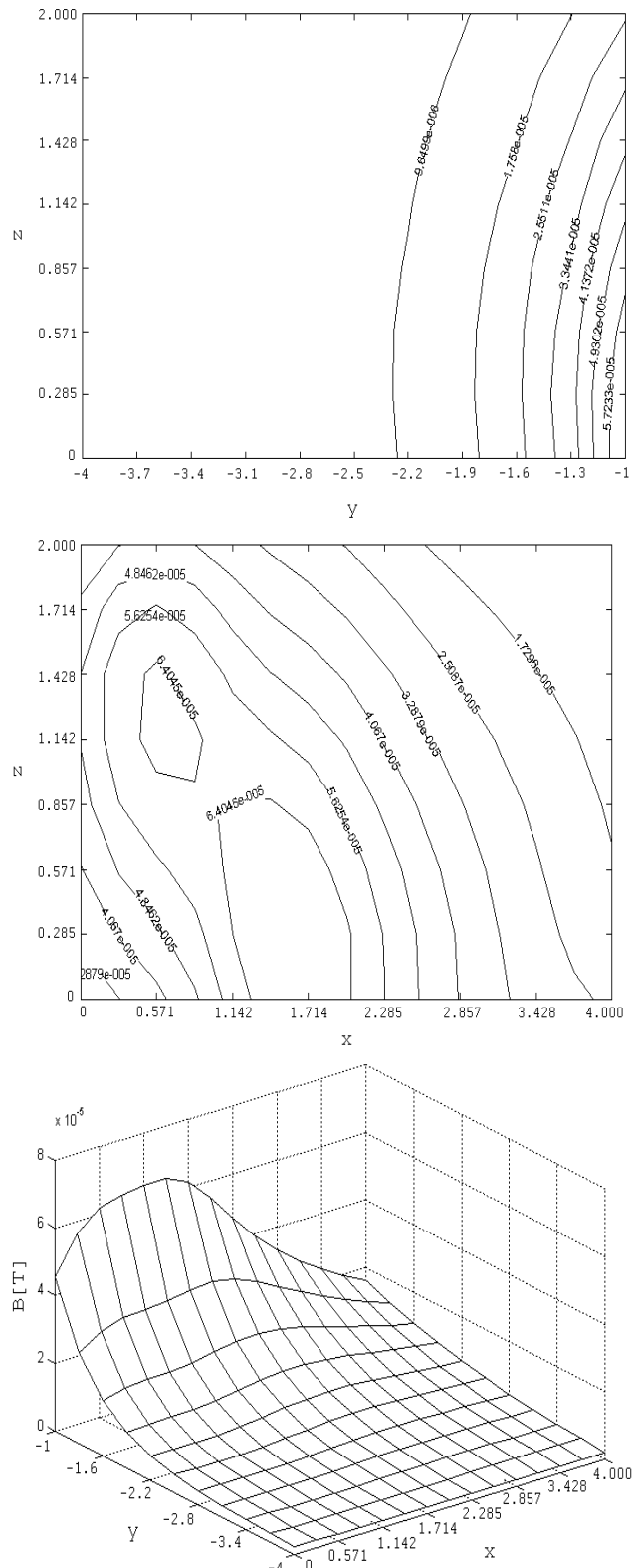

Figure 6. Magnetic flux density (T) generated, in the target volume, by the original configuration of the MV/LV cabin: a) contour plot on a yz plane at x = 2 m; b) contour plot on a xz plane at y = -1 m; c) surface plot on a xy plane at z = 1 m. All lengths are in m.

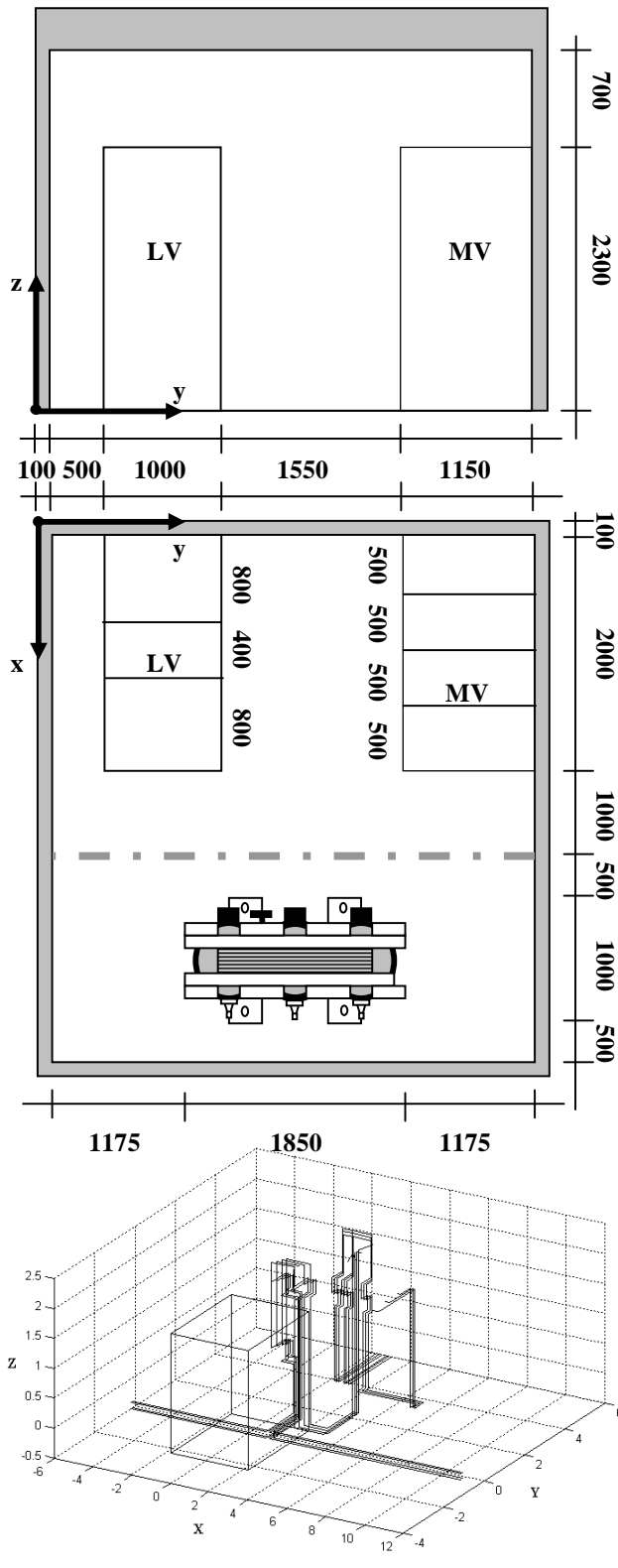

Figure 7. Layout (lengths in mm) and schematic 3D view (lengths in m) of the modified configuration of the MV/LV cabin under analysis. The PC has been shifted away from the wall (and then, the distance from the target volume has been increased of 500 mm).

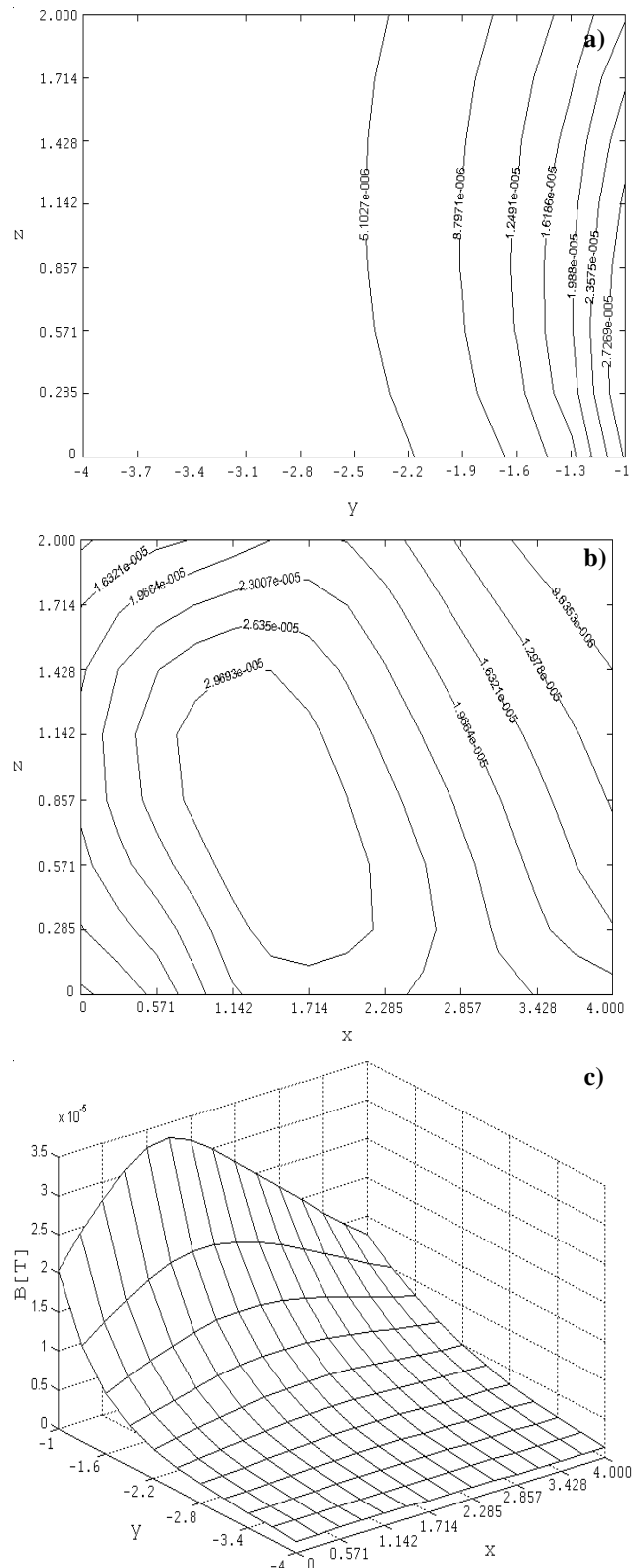

Figure 8. Magnetic flux density (T) generated, in the target volume, by the modified configuration of the MV/LV cabin: a) contour plot on a yz plane at  $x = 2$  m; b) contour plot on a xz plane at  $y = -1$  m; c) surface plot on a xy plane at  $z = 1$  m. All lengths are in m.

The geometrical configurations of the active shielding conductors have been limited to simple loops, each of which can also lie on two different planes (e.g., xz plane and/or yz plane). In this case, the conductors of the loop on the xz plane can be located, by the GA procedure, between the cabin wall and the PC, when it is shifted away from the wall of 500 mm (Figure 7) with respect to the original configuration (see Figure 5). While, the conductors of the loop on the yz plane may be located over the PC (e.g., between 2 m and 3 mm of height) or under PC (e.g., at 200 mm below the ground level).

A synthetic description of the GAs operative principles has been given before. We want now describe the GAs implementation for the 3D problem under analysis. Since the horizontal part of the compensating structure has been considered to be placed at 20 cm below the ground level, it is immediate to verify that the whole structure is localized when are given the coordinates (x, y, z) of one point of the upper side of the vertical loop, a coordinate (x) of the other point at the same height but at the opposite side, and finally one coordinate (y) of the extreme points of the horizontal buried loop of the structure. This means that the compensating structure is localized by means of 5 geometrical parameters.

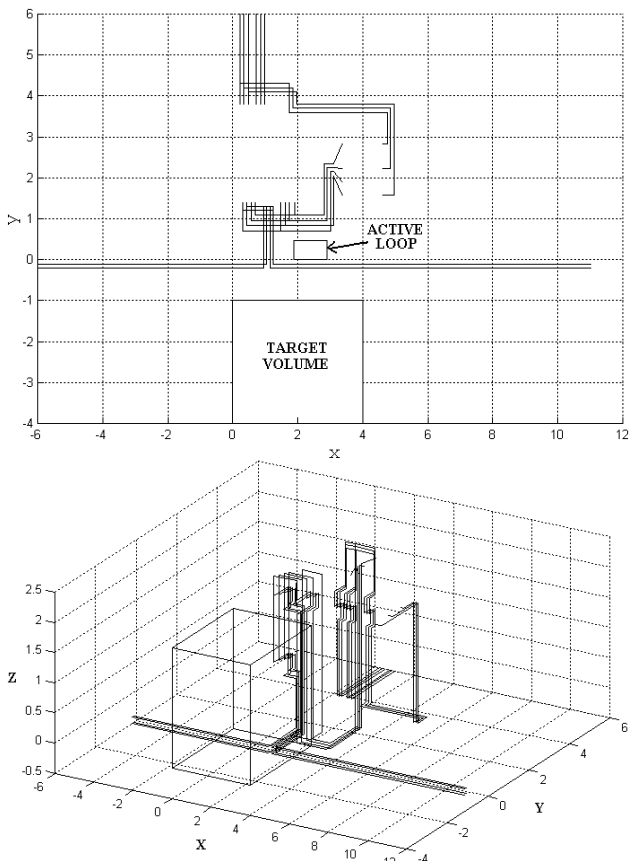

Figure 9. Layout and schematic 3D view of the modified cabin configuration completed with the active shielding loop. All lengths are in m.

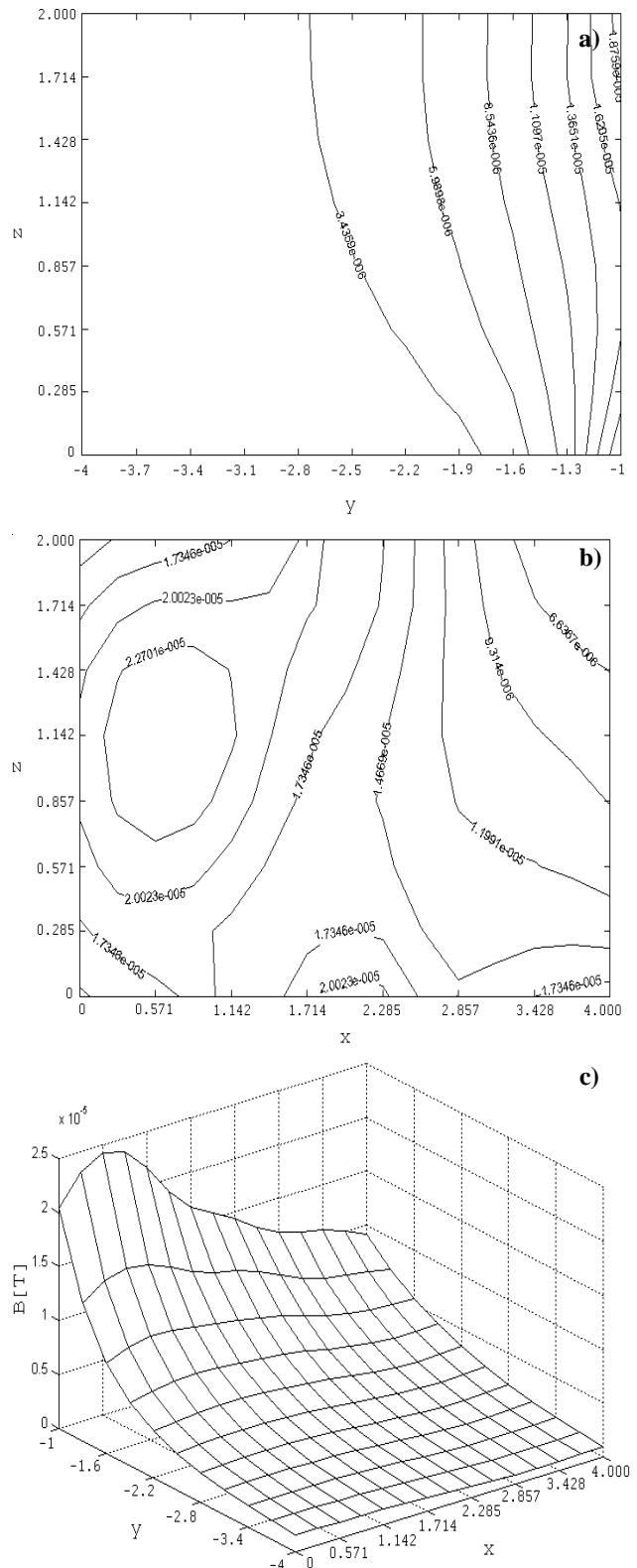

Figure 10. Magnetic flux density (T) generated, in the target volume, by the MV/LV cabin when the active loop is working: a) contour plot on a yz plane at  $x = 2$  m; b) contour plot on a xz plane at  $y = -1$  m; c) surface plot on a xy plane at  $z = 1$  m. All lengths are in m.

These parameters are represented by means of bits and it is necessary to choose the correct number of them, since a high number ensures a high precision but a slow velocity of the GA while a too low number of them ensure a high velocity of the GA but also a poor precision in the localization of the compensating structure (in fact, the optimal solution may be lost because of a not precise localization of the shielding loop). Due to the dimensions of the operative volume where the compensating structure can be placed (50 x 400 x 200 cm) a good compromise has demonstrated to the choice of 5 bits (32 values) to represent each geometrical parameter of compensating structure. It is also necessary to consider the current that flows inside the compensating structure. It is described in term of magnitude and phase. Since this current must varies as a function of the current that flows inside the conductors of the main busbar, its magnitude is represented as a percentage of the current that flows inside one of the mentioned conductors. The magnitude of this current has shown to be always less than 30% than the main current to obtain significant results and for this reason this percentage is represented using 5 bits (32 values). The phase of the current inside the compensating structure can vary between 0 and 360°: we choose to use 9 bits that allow of representing 512 numbers. Since the necessary numbers to codify the phase with a resolution equal to 1° are only 360, the remaining 152 values are used to represent the corresponding phase values between 0° and 152°, maintaining them active in the evolution process. A 8 bit encoding is not possible since it allows to represent only 256° with a resolution of 1° that is not enough for our purposes. The total length of the single chromosome is therefore equal to 39 bits. The magnetic flux density is numerically computed, during the evolution process, by means of a calculation code accounting for the fully 3D problem. The GA generates, at the end of the evolution process, optimal individuals, which correspond to geometrical arrangement of conductors and the related currents of the active shielding system that ensure the highest mitigation of magnetic flux density inside the target volume ( $0 < x < 4$  m,  $-4 < y < -1$  m,  $0 < z < 2$  m). A population of 100 individuals has shown to be sufficient to give good results in terms of computational performances of the GA procedure.

The geometrical configuration of the optimized shielding system is shown in Figure 9; while, in Figure 10, the magnetic flux density maps are plotted. These results have been compared with those (see Figure 6) referring to the original configuration (see Figure 5) and with those (see Figure 7) referring to the modified configuration (see Figure 8). Shifting away the PC from the wall of 500 mm (compare Figures 5 and 7), in such a way to make possible the location of the active shielding loop, the maximum value of the magnetic flux density is reduced of about 53% (from 72.1  $\mu$ T to 34  $\mu$ T). An additional reduction of this value, of about 28% (from 34  $\mu$ T to 24.3  $\mu$ T), has been obtained after the instal-

lation of the active shielding system. Thus, with respect to the original value, the total reduction of the maximum value of the magnetic flux density inside the target volume is of about 66% (from 72.1  $\mu$ T to 24.3  $\mu$ T). A quite similar trend has been obtained for the mean value of the magnetic flux density inside the target volume (this is the value which pilots the evolution of the GA optimization procedure).

## CONCLUSIONS

From the analysis of the results it is possible to conclude that the active shielding of indoor MV/LV substations can produce relevant reduction of the magnetic pollution in target volumes outside the cabins. This technique may be used both in new installations (when the magnetic flux density values are very critical in some regions outside the substations) and in existing cabins (when they must be accommodated in order to respect more restrictive limits on the maximum magnetic flux density admissible for human exposure). In addition, it has been also demonstrated that the GA optimization procedure, can be advantageously applied during the design of active shielding systems, which have the aim to mitigate, in assigned target volumes, the magnetic flux density produced by indoor MV/LV substations. The authors are working in order to generalize the proposed approach and to test its reliability in real cases (i.e., when the excitation currents are unbalanced and when these currents are also time varying).

## ACKNOWLEDGMENTS

This study has been financially supported by Provincia di Roma, Dipartimento n. 2 "Ambiente", Servizio n. 3 "Tutela dell'aria".

## REFERENCES

- [1] L. Hasselgren, J. Luomi, *Geometrical Aspects of Magnetic Shielding at Extremely Low Frequencies*, IEEE Trans. on EMC, 1995, pp. 409-420.
- [2] T. Rikitake, *Magnetic and Electromagnetic Shielding*, Terra Scientific Publishing Company, Tokyo, Japan, 1987.
- [3] S. Celozzi, "Active Compensation and Partial Shields for the Power-Frequency Magnetic Field Reduction", IEEE 2002 Int. Symp. on Electromagnetic Compatibility, Minneapolis, USA, pp. 222-226.
- [4] S. Celozzi, F. Garzia, "Active shielding for the power-frequency magnetic field reduction using genetic algorithm optimisation", submitted for publication.
- [5] A. Geri, A. Locatelli and G. M. Veca, *Magnetic fields generated by power lines*, IEEE Transactions on Magnetics, Vol. 31, No. 3, May 1995, pp 1508-1511
- [6] A. Geri and G. M. Veca, "Prediction of the magnetic pollution due to power lines", Conference Proceedings, III International Congress Energy, Environment and Technological Innovation, Caracas, Venezuela, 5-11 November, 1995, pp 253-258